



USER MANUAL

UP Series | Thermopile Power Detectors

WARRANTY

All Gentec-EO products carry a one-year warranty from the date of shipment on material or workmanship defects when used under normal operating conditions.

Gentec-EO will repair or replace, at its sole discretion, any product that proves to be defective during the warranty period.

The warranty does not cover damages caused by product misuse, product modifications, accidents, abnormal operating or handling conditions, or third-party battery leakage. Any attempt by an unauthorized person to alter or repair the product voids the warranty. Gentec-EO is not liable for consequential damages of any kind.

CLAIMS

For warranty service, please contact your Gentec-EO representative or fill out an RMA request:

<https://www.gentec-eo.com/contact-us/support-rma-request>

To help us answer your request more efficiently, please have your product serial number ready before contacting customer support.

Upon receipt of return authorization, ship the product according to the RMA instructions. Do not ship items without a return authorization. Transport is at the customer's expense, in both directions, unless the product has been received damaged or non-functional. Gentec-EO assumes no responsibility for the damage caused in transit.

TABLE OF CONTENTS

1.	UP AND XLP POWER DETECTORS.....	4
1.1.	Included with your UP/XLP	4
1.2.	Introduction.....	4
1.3.	Product name structure.....	5
1.4.	Absorbers	5
1.4.1.	H: General use, broadband absorber.....	5
1.4.2.	W: High energy density absorber	5
1.4.3.	QED: Diffusing absorber for high power density.....	5
1.4.4.	VP: Volume absorber for short pulses	5
1.4.5.	Absorptance curves for all absorbers	6
1.5.	Connectors and all-in-one meters.....	7
1.5.1.	"Smart" DB15 connector	7
1.5.2.	INT: Integra all-in-one meter with USB connector	7
1.5.3.	IDR: Integra all-in-one meter with RS232 connector	7
1.5.4.	Wireless connection: BLU series	7
1.5.5.	Custom connectors	8
1.6.	Specifications	10
1.6.1.	General specifications.....	10
1.6.2.	Footnotes	10
1.6.3.	XLP12.....	11
1.6.4.	UP10	12
1.6.5.	UP12	14
1.6.6.	UP17	15
1.6.7.	UP16, UP19	16
1.6.8.	UP25	19
1.6.9.	UP52, UP55(N)(M)	20
1.6.10.	UP55C	23
1.6.11.	UP55G	24
1.6.12.	UP100R	25
1.7.	Single-Shot Energy mode specifications	26
2.	OPERATING INSTRUCTIONS.....	28
2.1.	Quick-start guide	28
2.2.	Measurements without a Gentec-EO monitor	28
2.3.	Cooling water	29
2.4.	Storage notes	29
2.5.	Safety operation notes.....	29
2.5.1.	Diffusive surfaces	29
2.5.2.	Detector temperature while in operation.....	30
2.6.	Using a customer-supplied heatsink.....	30
3.	DAMAGE TO THE OPTICAL ABSORBER MATERIAL	32
3.1.	Damage threshold curves	32
4.	DECLARATION OF CONFORMITY.....	34
5.	UKCA DECLARATION OF CONFORMITY	35
	APPENDIX A: WEEE DIRECTIVE	36
	APPENDIX B: USING THE XLP12 WITH THE XLP12 FILTER	37
	APPENDIX C: USING THE XLP12 WITH AN OPTICAL FIBER ADAPTOR	38
	APPENDIX D. CUSTOM AND DISCONTINUED MODELS	39

1. UP AND XLP POWER DETECTORS

1.1. INCLUDED WITH YOUR UP/XLP

The following items are included with UP or XLP series laser power detectors:

Description	Part name	Part number
UP or XLP series laser power detector		
Protective cover		
Calibration certificate		
Personal wavelength correction™ certificate		
Power supply and country-specific AC cable (fan-cooled detectors only)	FAN-12V UPG-12V	See website
Isolation tube with SM1 thread (XLP only)	XLP12-TUBE	101449

The following items can be purchased separately:

Description	Part name	Part number
Stand	STAND-S-233 STAND-S-443 STAND-S-443-C	200160 200234 201102
Fiber adaptor*	See website	See website
Extension cable	Call	Call

***NOTE:** Gentec-EO detectors are calibrated in free-space conditions. Adding adaptors or accessories close to the absorber can offset the measurements.

1.2. INTRODUCTION

The Gentec-EO UP and XLP power detector family includes a large variety of opto-thermal sensors with different absorbers, aperture sizes, and cooling options. These detectors are designed to provide reliable measurements and high damage thresholds. Each detector is calibrated with traceable and certified methods to provide the best possible accuracy.

UP detectors are supplied with a 180 cm length flexible cable with output connection options of a smart DB15 male connector or an Integra meter (USB or RS232). Wireless (BLU) models do not have an attached cable. Customized detectors can be designed with different cable lengths or with other connectors, such as BNC, Molex, or BNC/Molex (see section 1.5).

NOTES: To eliminate possible damage, do not carry the detector using the connector cable.

Be aware that when using a detector with a heatsink, the fins should always be placed vertically.

For cases where your display or meter does not automatically read the wavelength correction factor, you can use your detector's "Personal wavelength correction™ certificate" to adjust the power you read to a power corrected for a particular wavelength.

Call your nearest Gentec-EO distributor to replace the sensor disk and/or to recalibrate the head.

1.3. PRODUCT NAME STRUCTURE

All products in the UP and XLP series are named using the same structure. The table below explains each part of the product name, with the following product as an example: UP55N-300F-H12-INT-D0

Thermopile type	Aperture	Enclosure	Max. power
UP	55	N	300
XLP: Axial UP: Radial	Diameter, in mm	Internal code for enclosure size and type	Maximum rated continuous power

Cooling	Absorber	All-in-one meter	Connector type
F	H12	INT	D0
S: Standalone H: Heatsink L: Large heatsink F: Fan-cooled W: Water-cooled DI: Water-cooled, for deionized water	H: Standard absorber W: High energy density absorber EZ: Cleanable absorber QED: Diffuser VP: Volume absorber	INT: Integra, USB IDR: Integra, RS232 BLU: Wireless (empty): no meter	D0: Standard (if no meter: DB15) <i>Custom:</i> MT: Amplified Molex M0: Molex, not amplified BT: Amplified Molex-BNC Etc.

1.4. ABSORBERS

1.4.1. H: General use, broadband absorber

Our standard absorber offers high damage thresholds and a flat spectral response, making this series of power detectors a versatile solution that can cover most of your laser power measurement needs.

1.4.2. W: High energy density absorber

Our “W” absorber can handle tightly focused beams, thanks to its extremely high damage threshold for average power density. It can be used to measure up to 50 W, from the UV to IR.

It is ideal for UV lasers and tightly focused beams.

1.4.3. QED: Diffusing absorber for high power density

Detectors with the QED absorber are designed for lasers with extreme power and energy density, such as laser micromachining systems. Thanks to a proprietary absorber that diffuses the measured beam and absorbs it in a larger volume, these detectors have the highest damage thresholds on the market.

NOTE: This absorber has a high level of back-reflections. Proper laser safety procedures must be used.

1.4.4. VP: Volume absorber for short pulses

Our VP absorber is only available in the XLP12 series. It is ideal for very short pulses.

1.4.5. Absorbance curves for all absorbers

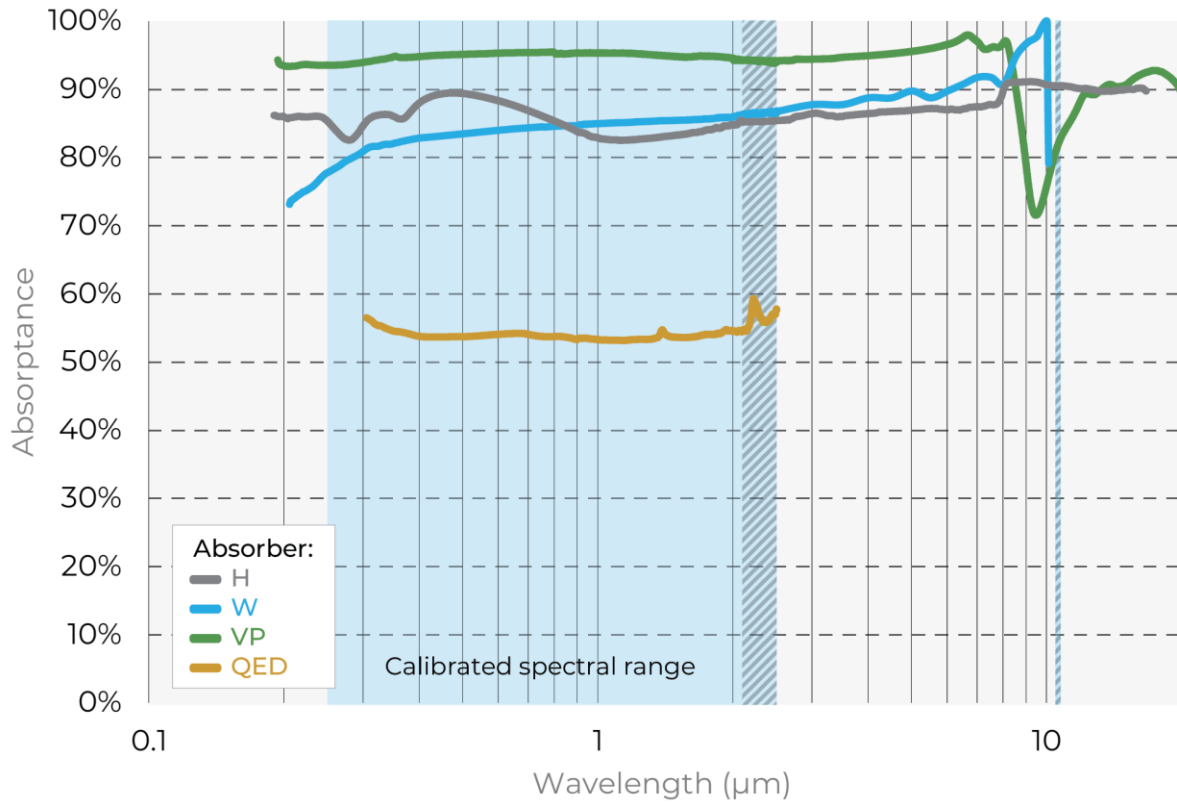

Fig. 1-1 Typical absorption curve for the available absorbers. The calibrated spectral range is indicated in light blue. Extra calibration ranges that can be purchased are indicated by the hatched areas. Note that the QED absorber has a limited spectral range; please refer to the specifications tables for more details.

1.5. CONNECTORS AND ALL-IN-ONE METERS

1.5.1. "Smart" DB15 connector

The smart DB15 male connector contains an EEPROM (Electrically Erasable Programmable Read-Only Memory) containing information such as the model of the detector, the calibration sensitivity, the applicable scales and the wavelength correction factor for up to 20 wavelengths related to the detector in use.

This connector allows Gentec-EO displays and PC interfaces to adjust their characteristics automatically to the connected power sensor. No calibration procedure is required when installing the power detectors, allowing for fast set-up.

The DB15 connector pin-out is composed of (see Fig. 1-2):

1-	USED BY MONITOR				
2-	"	"	"	"	"
3-	"	"	"	"	"
4-	"	"	"	"	"
5-	"	"	"	"	"
6-	SIGNAL (+)				
7-	USED BY MONITOR				
8-	"	"	"	"	"
9-	"	"	"	"	"
10-	"	"	"	"	"
11-	"	"	"	"	"
12-	"	"	"	"	"
13-	SIGNAL (-)				
14-	USED BY MONITOR				
15-	"	"	"	"	"
SHELL	-BODY GROUND				

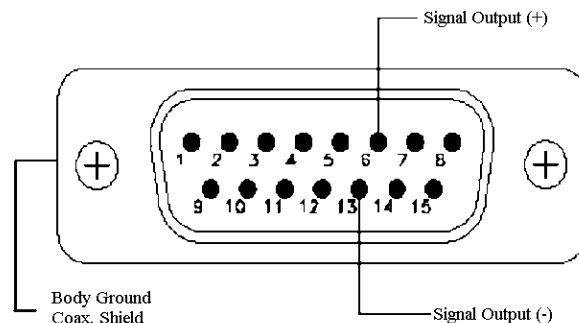

Fig. 1-2 DB15 connector pin-out

1.5.2. INT: Integra all-in-one meter with USB connector

Integra USB is an integrated meter that allows you to plug your detector directly into a computer. It communicates via serial commands (see the INTEGRA User Manual) and can use our free PC-Gentec-EO software. All specifications are the same as the DB15 version, except for:

- Wattmeter and joulemeter heads have a noise ~ 1.3 x higher.
- The risetime of the UP12 head (with anticipation) is slower by 0.2 seconds.

1.5.3. IDR: Integra all-in-one meter with RS232 connector

Integra RS232 is an integrated meter that allows you to plug your detector directly into a computer. It communicates via serial commands (see the INTEGRA User Manual) and can use our free PC-Gentec-EO software. All specifications are the same as the USB version.

1.5.4. Wireless connection: BLU series

BLU is a series of all-in-one detectors that combines a detector and a meter in one convenient product. BLU transmits your laser data through a Bluetooth low energy wireless link directly to the BLU mobile app running on your smartphone or tablet. You can also use the Bluetooth USB dongle supplied with your BLU power meter to connect it to the PC-Gentec-EO software on your PC. All specifications are the same as the DB15 version.

Almost all UP and XLP models are available for purchase with a BLU meter, except the following:

- UP19 models with the LARGE heatsink (L)
- UP10P-2S-H5-L and UPF10P-2S-H5-L

1.5.5. Custom connectors

BNC connector

The BNC connector is quick and easy to install and is the best at shielding EMI noise. This connector allows you to connect the detector directly to an oscilloscope or to a precision microvoltmeter with the correct load impedance. The connector is available in the UP detectors without amplification (load impedance: 100 k Ω) and with the Molex connector in the amplified version (load impedance : 10 M Ω).

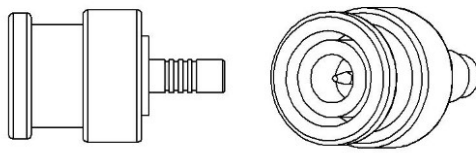

Fig. 1-3 BNC connector

E0: OEM Molex connector

The Molex female connector is available in the UP19-xxx-H5 and UP12E-xxx-H5 without amplification (load impedance : 100 k Ω). It allows you to connect to an external PCB board available at Gentec-E0.



Fig. 1-4 Molex connector pin-out in E0 version

MT: Molex connector

The Molex male connector, available in the UP with amplification, allows you to power the internal circuit board (PCB) and to read the signal with your own electronics. The PCB needs +12 to +16V from a regulated power supply but does not need negative voltage.



Fig. 1-5 Molex connector pin-out in MT version

BT: Molex-BNC

The Molex-BNC connection, available in the UP with amplification, allows you to power the internal circuit board (PCB) with the Molex connector and to read the signal with the BNC connector (load impedance: 10 M Ω). The PCB needs +12 to +16V from a regulated power supply but does not need negative voltage.

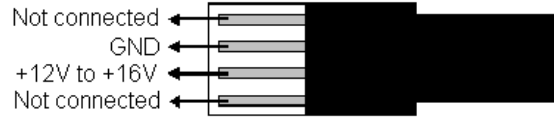

Fig. 1-6 Molex connector pin-out in BT version

M0: Molex connector without amplification or anticipation

The Molex male connector, available in the UP without amplification, allows you to read the signal with your own electronics.

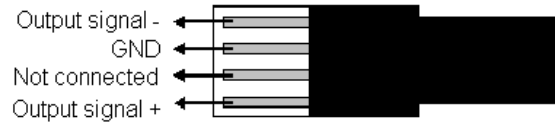

Fig. 1-7 Molex connector pin-out in M0 version

1.6. SPECIFICATIONS

1.6.1. General specifications

All following specifications are based on a one-year calibration cycle, an operating temperature of 15 to 28°C, and a relative humidity not exceeding 80 %. Store between 10 and 65°C, with relative humidity not exceeding 90 %.

Specifications are subject to change without notice.

All XLP and UP detectors	
Recommended load impedance when used with your own voltage measurement instrument	100 kΩ
Water-cooled detectors	
Water temperature	≤ 22°C
Water connections	1/8 NPT compression fittings for ¼ inch semi-rigid tube

1.6.2. Footnotes

Footnotes for the specifications tables are combined here:

- a. The traceability at 248 nm is obtained with the help of a traceable reference at 250 nm, since our spectrophotometer has a 4 nm spectral bandwidth at 248 nm.
- b. Except 1350 - 1450 nm.
- c. Both options will incur additional charges. It is not possible to have both 2.1 µm to 2.5 µm and 10.6 µm calibration added to a single detector. Contact a Gentec-EO representative to learn more about these calibration options or to get a quote for them.
- d. Nominal value, actual value depends on electrical noise in the measurement system.
- e. At 150 µW. 12 µW/°C for XLP12 with SOLO, 50 µW/°C for XLP12 with P-LINK.
- f. Including linearity with power
- g. 1 minute intermittent power specification requires 3 minutes cooling interval minimum.

1.6.3. XLP12

	XLP12-3S-H2	XLPF12-3S-H2	XLP12-3S-VP
Effective aperture diameter	12 mm		
Spectral range	0.19 - 20 μm	0.28 - 2.1 μm Uncoated UV fused silica is used as a filter window.	0.248 - 20 μm
Calibrated spectral range ^a	0.248 - 2.1 μm	0.308 - 2.1 μm ^b	0.248 - 2.1 μm
Available extra calibrated ranges ^c	2.1 - 2.5 μm <u>OR</u> 10.6 μm	None	2.1 - 2.5 μm <u>OR</u> 10.6 μm
Max. average power	3 W		
Power noise level ^d	$\pm 5 \mu\text{W}$ with anticipation $\pm 0.5 \mu\text{W}$ without anticipation		
Thermal drift ^e	12 $\mu\text{W}/^\circ\text{C}$	6 $\mu\text{W}/^\circ\text{C}$	12 $\mu\text{W}/^\circ\text{C}$
Typical rise time (0-95 %)	2.5 s		3.0 s
Natural rise time (0-95 %)	27 s		30 s
Typical sensitivity	200 mV/W	180 mV/W	220 mV/W
Calibration uncertainty ^f	$\pm 2.0 \%$ (1064 – 1070 nm) $\pm 4.1 \%$ (248 – 299 nm) $\pm 3.0 \%$ (300 – 1565 nm) $\pm 4.0 \%$ (1566 – 2100 nm)		$\pm 2.5 \%$ (1064 nm) $\pm 3.5 \%$ (250 – 2500 nm)
Linearity with power	$\pm 2 \%$		
Repeatability (precision)	$\pm 0.5 \%$		
Linearity vs beam dimension	$\pm 0.7 \%$		
Minimum repetition rate	20 Hz with anticipation 5 Hz without anticipation		7 Hz with anticipation 1 Hz without anticipation
Max. average power density 1.064 μm , 1 W CW 532 nm, 1 W CW 355 nm, 1 W CW	1 kW/cm ² - -		30 W/cm ² 8 W/cm ² 4 W/cm ²
Pulsed laser damage thresholds 1.064 μm , 360 μs , 5 Hz 1.064 μm , 7 ns, 10 Hz 532 nm, 7 ns, 10 Hz 266 nm, 7 ns, 10 Hz	5 J/cm ² 1 J/cm ² 0.6 J/cm ² 0.3 J/cm ²		- 4 J/cm ² 3 J/cm ² 1 J/cm ²
Cooling	Stand-alone		
Dimensions (H x W x D, mm)	With isolation tube: 73 x 73 x 72 Without isolation tube: 73 x 73 x 20		
Weight (head only, with isolation tube)	0.312 kg	0.324 kg	0.316 kg

1.6.4. UP10

	UP10P-2S-H5-L	UPF10P-2S-H5-L
Effective aperture diameter	10 mm	
Aperture threading	1.035"-40 (SM1)	
Spectral range	0.19 – 20 μm	0.28 – 2.1 μm
Calibrated spectral range ^a	0.248 – 2.1 μm	0.308 – 2.1 μm ^b
Available extra calibrated ranges ^c	2.1 - 2.5 μm <u>OR</u> 10.6 μm	None
Max. average power	2 W	
Power noise level	± 0.2 mW with anticipation ± 0.1 mW without anticipation ± 30 μW with anticipation and moving average mode (2 sec)	
Typical rise time (0-95 %)	1.4 s	
Natural rise time (0-95 %)	3.0 s	
Typical sensitivity	2 mV/W	1.8 mV/W
Calibration uncertainty ^f	± 2.5 % (1064 – 1070 nm) ± 4.3 % (248 – 299 nm) ± 3.3 % (300 – 1565 nm) ± 4.2 % (1566 – 2100 nm)	
Linearity with power	± 2 %	
Repeatability (Precision)	± 0.5 %	
Linearity vs beam dimension	± 0.7 %	
Max. average power density 1.064 μm , 2 W CW 10.6 μm , 2 W CW	36 kW/cm ² 11 kW/cm ²	
Pulsed laser damage thresholds 1.064 μm , 360 μs , 5 Hz 1.064 μm , 7 ns, 10 Hz 532 nm, 7 ns, 10 Hz 266 nm, 7 ns, 10 Hz	5 J/cm ² 1.0 J/cm ² 0.6 J/cm ² 0.3 J/cm ²	
Cooling	Stand-alone	
Dimensions (H x W x D, mm)	46 x 46 x 13	46 x 46 x 21.4
Weight (head only)	0.13 kg	0.14 kg

	UP10K-2S-H5-L	UPF10K-2S-H5-L
Effective aperture diameter	10 mm	
Aperture threading	1.035"-40 (SM1)	
Spectral range	0.19 - 20 μm	0.28 - 2.1 μm
Calibrated spectral range ^a	0.248 - 2.1 μm	0.308 - 2.1 μm ^b
Available extra calibrated ranges ^c	2.1 - 2.5 μm <u>OR</u> 10.6 μm	None
Max. average power	2 W	
Power noise level	± 0.2 mW with anticipation ± 0.1 mW without anticipation ± 30 μW with anticipation and moving average mode (2 sec)	
Typical rise time (0-95 %)	1.1 s	
Natural rise time (0-95 %)	3.0 s	
Typical sensitivity	2 mV/W	1.8 mV/W
Calibration uncertainty ^f	± 2.5 % (1064 – 1070 nm) ± 4.3 % (248 – 299 nm) ± 3.3 % (300 – 1565 nm) ± 4.2 % (1566 – 2100 nm)	
Linearity with power	± 2 %	
Repeatability (precision)	± 0.5 %	
Linearity vs beam dimension	± 0.7 %	
Max. average power density 1.064 μm , 2 W CW 10.6 μm , 2 W CW	36 kW/cm ² 11 kW/cm ²	
Pulsed laser damage thresholds 1.064 μm , 360 μs , 5 Hz 1.064 μm , 7 ns, 10 Hz 532 nm, 7 ns, 10 Hz 266 nm, 7 ns, 10 Hz	5 J/cm ² 1.0 J/cm ² 0.6 J/cm ² 0.3 J/cm ²	
Cooling	Stand-alone	
Dimensions (H x W x D, mm)	50 x 50 x 21.5	50 x 50 x 30
Weight (head only)	0.13 kg	0.14 kg

1.6.5. UP12

	UP12E-10S-H5	UP12E-20H-H5	UP12E-70W-H5
Effective aperture diameter	12 mm		
Spectral range	0.19 – 20 μm		
Calibrated spectral range ^a	0.248 - 2.1 μm		
Available extra calibrated ranges ^c	2.1 - 2.5 μm <u>OR</u> 10.6 μm		
Max. average power ^g	10 W (20 W for 1 min)	20 W (40 W for 1 min)	70 W (110 W for 1 min)
Power noise level	± 2 mW with anticipation ± 1 mW without anticipation		
Typical rise time (0-95 %)	0.3 s		
Natural rise time (0-95 %)	1.6 s		
Typical sensitivity	0.53 mV/W		
Calibration uncertainty ^f	± 2.5 % (1064 – 1070 nm) ± 4.3 % (248 – 299 nm) ± 3.3 % (300 – 1565 nm) ± 4.2 % (1566 – 2100 nm)		
Linearity with power	± 2 %		
Repeatability (precision)	± 0.5 %		
Linearity vs beam dimension	± 0.7 %		
Max. average power density 1.064 μm , 10 W CW 10.6 μm , 10 W CW	36 kW/cm ² 11 kW/cm ²		
Pulsed laser damage thresholds 1.064 μm , 360 μs , 5 Hz 1.064 μm , 7 ns, 10 Hz 532 nm, 7 ns, 10 Hz 266 nm, 7 ns, 10 Hz	5 J/cm ² 1.0 J/cm ² 0.6 J/cm ² 0.3 J/cm ²		
Recommended cooling flow	N/A		1.0 L/min (0.5 L/min minimum)
Cooling	Stand-alone	Heatsink	Water
Dimensions (H x W x D, mm)	38 x 38 x 14	38 x 38 x 45	38 x 38 x 32
Weight (head only)	0.13 kg	0.15 kg	0.19 kg

1.6.6. UP17

	UP17P-6S-H5	UP17P-6S-W5
Effective aperture diameter	17 mm	
Spectral range	0.19 - 20 μm	0.19 - 10 μm
Calibrated spectral range ^a	0.248 – 2.1 μm	
Available extra calibrated ranges ^c	2.1 - 2.5 μm <u>QR</u> 10.6 μm	2.1 - 2.5 μm
Max. average power ^g	6 W (7 W for 1 min)	
Power noise level ^d	± 2 mW with anticipation ± 1 mW without anticipation	
Typical rise time (0-95 %)	0.8 s	1.4 s
Natural rise time (0-95 %)	2.5 s	5 s
Typical sensitivity	0.6 mV/W	
Calibration uncertainty ^f	± 2.5 % (1064 – 1070 nm) ± 4.3 % (248 – 299 nm) ± 3.3 % (300 – 1565 nm) ± 4.2 % (1566 – 2100 nm)	
Linearity with power	± 2 %	
Repeatability (precision)	± 0.5 %	
Linearity vs beam dimension	± 0.5 %	
Max. average power density 1.064 μm , 10 W CW 10.6 μm , 10 W CW	36 kW/cm ² 11 kW/cm ²	100 kW/cm ² -
Pulsed laser damage thresholds 1.064 μm , 360 μs , 5 Hz 1.064 μm , 7 ns, 10 Hz 532 nm, 7 ns, 10 Hz 266 nm, 7 ns, 10 Hz	5 J/cm ² 1.0 J/cm ² 0.6 J/cm ² 0.3 J/cm ²	100 J/cm ² 1.1 J/cm ² 1.1 J/cm ² 0.7 J/cm ²
Cooling	Stand-alone	
Dimensions (H x W x D, mm)	46 x 46 x 10.7	
Weight (head only)	0.1 kg	

1.6.7. UP16, UP19

	UP16K-15S-QED	UP16K-30H-QED	UP16K-100W-QED
Effective aperture diameter	16 mm		
Spectral range	0.266 - 2.5 μm		
Calibrated spectral range	0.532 - 2.1 μm		
Available extra calibrated ranges ^c	2.1 - 2.5 μm		
Max. average power ^g	15 W (20 W for 1 min)	30 W (35 W for 1 min)	100 W
Power noise level	± 6 mW with anticipation ± 4 mW without anticipation		
Typical Rise time (0-95 %)	2.5 s		
Natural rise time (0-95 %)	7 s		
Typical sensitivity	0.11 mV/W		
Calibration uncertainty ^f	± 2.5 % (1064 – 1070 nm) ± 4.1 % (532 – 1565 nm) ± 5.0 % (1566 – 2100 nm)		
Linearity with power	± 2 %		
Repeatability (precision)	± 0.5 %		
Linearity vs beam dimension	± 0.5 %		
Max. average power density 1.064 μm , 10 W CW	100 kW/cm ²		
Pulsed laser damage thresholds 1.064 μm , 360 μs , 5 Hz 1.064 μm , 7 ns, single shot 1.064 μm , 7 ns, 10 Hz 532 nm, 7 ns, 10 Hz 266 nm, 7 ns, 10 Hz	300 J/cm ² 16 J/cm ² 8 J/cm ² 6 J/cm ² 1 J/cm ²		
Recommended cooling flow	N/A		1.0 L/min (0.5 L/min minimum)
Cooling	Stand-alone	Heatsink	Water
Dimensions (H x W x D, mm)	50 x 50 x 23.6	50 x 50 x 59.3	50 x 50 x 36
Weight (head only)	0.16 kg	0.21 kg	0.24 kg

	UP19K-15S-H5	UP19K-30H-H5	UP19K-50L-H5	UP19K-110F-H9	UP19K-200W-H9
Effective aperture diameter	19 mm				
Aperture threading	0.782"-32 Optional cover plate available with SM1 thread and 10 mm aperture				
Spectral range	0.19 - 20 μm				
Calibrated spectral range ^a	0.248 - 2.1 μm				
Available extra calibrated ranges ^c	2.1 - 2.5 μm <u>OR</u> 10.6 μm				
Max. average power ^g	15 W (30 W for 1 min)	30 W (60 W for 1 min)	50 W (90 W for 1 min)	110 W (150 W for 1 min)	200 W
Power noise level	± 2 mW with anticipation ± 1 mW without anticipation			± 6 mW with anticipation ± 3 mW without anticipation	
Typical rise time (0-95 %)	0.6 s			1.5 s	
Natural rise time (0-95 %)	2.8 s			4.5 s	
Typical sensitivity	0.65 mV/W			0.23 mV/W	
Calibration uncertainty ^f	± 2.5 % (1064 – 1070 nm) ± 4.3 % (248 – 299 nm) ± 3.3 % (300 – 1565 nm) ± 4.2 % (1566 – 2100 nm)				
Linearity with power	± 2 %				
Repeatability (precision)	± 0.5 %				
Linearity vs beam dimension	± 0.5 %				
Max. average power density 1.064 μm , 10 W CW 10.6 μm , 10 W CW	36 kW/cm ² 11 kW/cm ²			45 kW/cm ² 14 kW/cm ²	
Pulsed laser damage thresholds 1.064 μm , 360 μs , 5 Hz 1.064 μm , 7 ns, 10 Hz 532 nm, 7 ns, 10 Hz 266 nm, 7 ns, 10 Hz	5 J/cm ² 1.0 J/cm ² 0.6 J/cm ² 0.3 J/cm ²			9 J/cm ² 1.0 J/cm ² 0.6 J/cm ² 0.3 J/cm ²	
Recommended cooling flow	N/A				1.0 L/min (0.5 L/min minimum)
Cooling	Stand-alone	Heatsink	Heatsink	Fan	Water
Dimensions (H x W x D, mm)	50 x 50 x 20.6	50 x 50 x 56.3	76.2 x 76.2 x 73.6	50 x 50 x 62.8	50 x 50 x 33
Weight (head only)	0.16 kg	0.21 kg	0.48 kg	0.25 kg	0.24 kg

	UP19K-15S-W5	UP19K-30H-W5	UP19K-50L-W5	UP19K-50F-W5	UP19K-50W-W5
Effective aperture diameter	19 mm				
Aperture threading	0.782"-32 Optional cover plate available with SM1 thread and 10 mm aperture				
Spectral range	0.19 - 10 μm				
Calibrated spectral range ^a	0.248 - 2.1 μm				
Available extra calibrated ranges ^c	2.1 - 2.5 μm				
Max. average power ^g	15 W (30 W for 1 min)	30 W (60 W for 1 min)	50 W (85 W for 1 min)	50 W (85 W for 1 min)	50 W (85 W for 1 min)
Power noise level	± 2 mW with anticipation ± 1 mW without anticipation				
Typical rise time (0-95 %)	1.4 s				
Natural rise time (0-95 %)	5 s				
Typical sensitivity	0.65 mV/W				
Calibration uncertainty ^f	± 2.5 % (1064 – 1070 nm) ± 4.3 % (248 – 299 nm) ± 3.3 % (300 – 1565 nm) ± 4.2 % (1566 – 2100 nm)				
Linearity with power	± 2 %				
Repeatability (precision)	± 0.5 %				
Linearity vs beam dimension	± 0.5 %				
Max. average power density 1.064 μm , 10 W CW	100 kW/cm ²				
Pulsed laser damage thresholds 1.064 μm , 150 μs , 10 Hz 1.064 μm , 7 ns, 10 Hz 532 nm, 7 ns, 10 Hz 248 nm, 26 ns, 10 Hz	100 J/cm ² 1.1 J/cm ² 1.1 J/cm ² 0.7 J/cm ²				
Recommended cooling flow	N/A				1.0 L/min (0.5 L/min minimum)
Cooling	Stand-alone	Heatsink	Heatsink	Fan	Water
Dimensions (H x W x D, mm)	50 x 50 x 20.6	50 x 50 x 56.3	76.2 x 76.2 x 73.6	54.2 x 54.2 x 55.6	50 x 50 x 33
Weight (head only)	0.16 kg	0.21 kg	0.48 kg	0.25 kg	0.24 kg

1.6.8. UP25

	UP25N-40S-H9	UP25N-100H-H9	UP25N-250F-H12	UP25M-350W-H12
Aperture diameter	25 mm			
Aperture threading	1.035"-40 (SM1), only from serial number 340900 1.0625"-28, for serial numbers prior to 340900			
Spectral range	0.19 - 20 μm			
Calibrated spectral range ^a	0.248 - 2.1 μm			
Available extra calibrated ranges ^c	2.1 - 2.5 μm <u>QR</u> 10.6 μm			
Max. average power ^g	40 W (80 W for 1 min)	100 W (200 W for 1 min)	250 W (300 W for 1 min)	350 W
Power noise level	± 6 mW with anticipation ± 3 mW without anticipation		± 20 mW with anticipation ± 10 mW without anticipation	
Typical rise time (0-95 %)	1.3 s			
Natural rise time (0-95 %)	5 s		7.9 s	
Typical sensitivity	0.23 mV/W		0.1 mV/W	
Calibration uncertainty ^f	± 2.5 % (1064 – 1070 nm) ± 4.3 % (248 – 299 nm) ± 3.3 % (300 – 1565 nm) ± 4.2 % (1566 – 2100 nm)			
Linearity with power	± 2 %			
Repeatability (precision)	± 0.5 %			
Linearity vs beam dimension	± 0.5 %			
Max. average power density 1.064 μm , 10 W CW 10.6 μm , 10 W CW	45 kW/cm ² 14 kW/cm ²			
Pulsed laser damage thresholds 1.064 μm , 360 μs , 5 Hz 1.064 μm , 7 ns, 10 Hz 532 nm, 7 ns, 10 Hz 266 nm, 7 ns, 10 Hz	9 J/cm ² 1.0 J/cm ² 0.6 J/cm ² 0.3 J/cm ²			
Minimum cooling flow	N/A			1.5 L/min
Cooling	Stand-alone	Heatsink	Fan	Water
Dimensions (H x W x D, mm)	89 x 89 x 32	89 x 89 x 106	89 x 89 x 116	89 x 89 x 40
Weight (head only)	0.68 kg	0.99 kg	1.44 kg	0.87 kg

1.6.9. UP52, UP55(N)(M)

	UP52N-50S-QED	UP52N-100H-QED	UP52N-150F-QED	UP52M-300W-QED
Aperture diameter	52 mm			
Spectral range	0.266 - 2.5 μm			
Calibrated spectral range	0.300 - 2.1 μm			
Available extra calibrated ranges ^c	2.1 - 2.5 μm			
Max. average power	50 W	100 W	150 W	300 W
Power noise level	± 30 mW with anticipation ± 15 mW without anticipation			
Typical rise time (0-95 %)	4 s			
Natural rise time (0-95 %)	15 s			
Typical sensitivity	0.06 mV/W			
Calibration uncertainty ^f	± 2.5 % (1064 – 1070 nm) ± 4.1 % (300 – 1565 nm) ± 5.0 % (1566 – 2100 nm)			
Linearity with power	± 2 %			
Repeatability (precision)	± 0.5 %			
Linearity vs beam dimension	± 0.5 %			
Max. average power density 1.064 μm , 10 W CW	100 kW/cm ²			
Pulsed laser damage thresholds 1.064 μm , 360 μs , 5 Hz 1.064 μm , 7 ns, single shot 1.064 μm , 7 ns, 10 Hz 532 nm, 7 ns, 10 Hz 266 nm, 7 ns, 10 Hz	300 J/cm ² 16 J/cm ² 8 J/cm ² 6 J/cm ² 1 J/cm ²			
Minimum cooling flow	N/A			1 L/min
Cooling	Stand-alone	Heatsink	Fan	Water
Dimensions (H x W x D, mm)	89 x 89 x 32	89 x 89 x 106	89 x 89 x 116	89 x 89 x 40
Weight (head only)	0.62 kg	0.93 kg	1.41 kg	0.84 kg

	UP55N-40S-H9	UP55N-100H-H9	UP55N-300F-H12	UP55M-500W-H12	UP55M-700W-HD
Aperture diameter	55 mm				
Spectral range	0.19 - 20 μm				
Calibrated spectral range ^a	0.248 - 2.1 μm				
Available extra calibrated ranges ^c	2.1 - 2.5 μm <u>QR</u> 10.6 μm				
Max. average power ^g	40 W (80 W for 1 min)	100 W (200 W for 1 min)	300 W	500 W	700 W
Power noise level	± 10 mW with anticipation ± 5 mW without anticipation		± 30 mW with anticipation ± 15 mW without anticipation		± 90 mW with anticipation ± 45 mW without anticipation
Typical rise time (0-95 %)	2 s				2.8 s
Natural rise time (0-95 %)	11 s		18 s		14 s
Typical sensitivity	0.12 mV/W		0.06 mV/W		0.03 mV/W
Calibration uncertainty ^f	± 2.5 % (1064 – 1070 nm) ± 4.3 % (248 – 299 nm) ± 3.3 % (300 – 1565 nm) ± 4.2 % (1566 – 2100 nm)				
Linearity with power	± 2 %				
Repeatability (precision)	± 0.5 %				
Linearity vs beam dimension	± 0.5 %				
Max. average power density 1.064 μm , 10 W CW 10.6 μm , 10 W CW	45 kW/cm ² 14 kW/cm ²				
Pulsed laser damage thresholds 1.064 μm , 360 μs , 5 Hz 1.064 μm , 7 ns, 10 Hz 532 nm, 7 ns, 10 Hz 266 nm, 7 ns, 10 Hz	9 J/cm ² 1.0 J/cm ² 0.6 J/cm ² 0.3 J/cm ²				
Minimum cooling flow	N/A			1.5 L/min	
Cooling	Stand-alone	Heatsink	Fan	Water	Water
Dimensions (H x W x D, mm)	89 x 89 x 32	89 x 89 x 106	89 x 89 x 116	89 x 89 x 40	89 x 89 x 40
Weight (head only)	0.62 kg	0.93 kg	1.41 kg	0.81 kg	0.90 kg

	UP55N-40S-W9	UP55N-50H-W9	UP55N-50F-W9	UP55M-50W-W9
Aperture diameter	55 mm			
Spectral range	0.19 - 10 μm			
Calibrated spectral range ^a	0.248 - 2.1 μm			
Available extra calibrated ranges ^c	2.1 - 2.5 μm			
Max. average power ^g	40 W (80 W for 1 min)	50 W (85 W for 1 min)	50 W (85 W for 1 min)	50 W (85 W for 1 min)
Power noise level	± 10 mW with anticipation ± 5 mW without anticipation			
Typical rise time (0-95 %)	3.5 s			
Natural rise time (0-95 %)	16 s			
Typical sensitivity	0.12 mV/W			
Calibration uncertainty ^f	± 2.5 % (1064 – 1070 nm) ± 4.3 % (248 – 299 nm) ± 3.3 % (300 – 1565 nm) ± 4.2 % (1566 – 2100 nm)			
Linearity with power	± 2 %			
Repeatability (precision)	± 0.5 %			
Linearity vs beam dimension	± 0.5 %			
Max. average power density 1.064 μm , 10 W CW	100 kW/cm ²			
Pulsed laser damage thresholds 1.064 μm , 150 μs , 5 Hz 1.064 μm , 7 ns, 10 Hz 532 nm, 7 ns, 10 Hz 248 nm, 26 ns, 10 Hz	100 J/cm ² 1.1 J/cm ² 1.1 J/cm ² 0.7J/cm ²			
Minimum cooling flow ^c	N/A			1 L/min
Cooling	Stand-alone	Heatsink	Fan	Water
Dimensions (H x W x D, mm)	89 x 89 x 32	89 x 89 x 106	89 x 89 x 116	89 x 89 x 40
Weight (head only)	0.62 kg	0.93 kg	1.41 kg	0.81 kg

1.6.10. UP55C

	UP55C-2.5KW-HD	
Effective aperture diameter	55 mm	
Spectral range	0.19 - 20 μm	
Calibrated spectral range ^a	0.248 - 2.1 μm	
Available extra calibrated ranges ^c	2.1 - 2.5 μm	
Max. average power	2500 W	
Power noise level	± 0.4 W with anticipation ± 0.2 W without anticipation	
Typical rise time (0-95 %)	3.5 s	
Natural rise time (0-95 %)	25 s	
Typical sensitivity	8 $\mu\text{V/W}$	
Calibration uncertainty ^f	± 2.5 % (1064 – 1070 nm) ± 4.3 % (248 – 299 nm) ± 3.3 % (300 – 1565 nm) ± 4.2 % (1566 – 2100 nm)	
Linearity with power	± 2 %	
Repeatability (precision)	± 0.5 %	
Linearity vs beam dimension	± 1 %	
Max. average power density	1.064 μm	10.6 μm
500 W CW	9.0 kW/cm ²	4.5 kW/cm ²
1500 W CW	7.0 kW/cm ²	3.5 kW/cm ²
2500 W CW	6.0 kW/cm ²	3.0 kW/cm ²
Pulsed laser damage thresholds	1.0 J/cm ²	
1064 nm, 7 ns, 10 Hz	0.6 J/cm ²	
532 nm, 7 ns, 10 Hz		
Cooling	Water	
Recommended cooling flow	3 – 4 L/min	
Dimensions (H x W x D, mm)	116 x 116 x 48	
Weight (head only)	3.30 kg	

1.6.11. UP55G

	UP55G-600F-HD
Effective aperture diameter	55 mm
Aperture threading	2 ¼" - 20
Spectral range	0.19 - 20 µm
Calibrated spectral range ^a	0.248 - 2.1 µm
Available extra calibrated ranges ^c	2.1 - 2.5 µm <u>OR</u> 10.6 µm
Max. average power	600 W
Power noise level	± 90 mW with anticipation ± 45 mW without anticipation
Typical rise time (0-95 %)	5 s
Natural rise time (0-95 %)	14 s
Typical sensitivity	0.03 mV/W
Calibration uncertainty ^f	± 2.5 % (1064 – 1070 nm) ± 4.3 % (248 – 299 nm) ± 3.3 % (300 – 1565 nm) ± 4.2 % (1566 – 2100 nm)
Linearity with power	± 2%
Repeatability (precision)	± 0.5%
Linearity vs beam dimension	± 0.5 %
Max. average power density 1.064 µm, 10 W, CW 1.064 µm, 500 W, CW	45 kW/cm ² 8 kW/cm ²
Pulsed laser damage thresholds 1.064 µm, 360 µs, 5 Hz 1.064 µm, 7 ns, 10 Hz 532 nm, 7 ns, 10 Hz 266 nm, 7 ns, 10 Hz	9 J/cm ² 1.0 J/cm ² 0.6 J/cm ² 0.3 J/cm ²
Cooling	Fan
Dimensions (H x W x D, mm)	120 x 120 x 135
Weight (head only)	2.75 kg

1.6.12. UP100R

	UP100R-50S-H12
Effective aperture diameter	100 mm
Spectral range	0.19 - 20 μm
Calibrated spectral range ^a	0.248 - 2.1 μm
Available extra calibrated ranges ^c	2.1 - 2.5 μm <u>OR</u> 10.6 μm
Max. average power	50 W (100 W for 1 min)
Power noise level	± 120 mW with anticipation ± 20 mW without anticipation
Typical rise time (0-95 %)	5 s
Natural rise time (0-95 %)	30 s
Typical sensitivity	0.02 mV/W
Calibration uncertainty ^f	± 2.5 % (1064 – 1070 nm) ± 4.3 % (248 – 299 nm) ± 3.3 % (300 – 1565 nm) ± 4.2 % (1566 – 2100 nm)
Linearity with power	± 2 %
Repeatability (precision)	± 0.5 %
Linearity vs beam dimension	± 1 %
Max average power density 1.064 μm , 10 W CW 10.6 μm , 10 W CW	45 kW/cm ² 14 kW/cm ²
Pulsed laser damage thresholds 1.064 μm , 360 μs , 5 Hz 1.064 μm , 7 ns, 10 Hz 532 nm, 7 ns, 10 Hz 266 nm, 7 ns, 10 Hz	9 J/cm ² 1.0 J/cm ² 0.6 J/cm ² 0.3 J/cm ²
Cooling	Stand-alone
Dimensions (H x W x D, mm)	125 x 125 x 17
Weight (head only)	0.50 kg

1.7. SINGLE-SHOT ENERGY MODE SPECIFICATIONS

The XLP and UP series have an optional mode that is called Single-Shot Energy mode (SSE). It allows you to measure single-shot pulse energy. This mode is accessible when you use a UP or XLP with a Gentec-EO monitor or with your own data acquisition system. For more information, refer to the monitor's instruction manual or contact customer support.

		XLP(F) H2	UP12E H5	UP10P H5	UP10K H5	UP16K QED
Typical sensitivity	mV/J	25 F : 22.5	0.84	2.4	2.4	0.11
Power sensitivity / energy sensitivity	J/W	8	0.63	0.81	0.81	1
Typical rise time in SSE mode	ms	1000	150	190	190	185
Minimum repetition period	sec	16	1.5	2	2	4
Maximum pulse width	ms	300	50	63	63	61
Maximum measurable energy ^a	J	5	5	3	3	500
Noise equivalent energy	mJ	0.012	20	5	5	60
Accuracy	%	± 5	± 5	± 5	± 5	± 5

		UP17P H5	UP17P W5	UP19K H5	UP19K H9	UP19K VR	UP19K W5
Typical sensitivity	mV/J	0.7	0.2	0.65	0.23	0.10	0.33
Power sensitivity / energy sensitivity	J/W	0.86	3	0.99	1	3.4	2
Typical rise time in SSE mode	ms	328	575	264	264	270	400
Minimum repetition period	sec	4	5	4	4	4.5	5
Maximum pulse width	ms	88	133	88	88	90	133
Maximum measurable energy ^a	J	15	200	15	25	40	200
Noise equivalent energy	mJ	20	20	20	60	20	23
Accuracy	%	± 5	± 5%	± 5%	± 5%	± 5	± 5

		UP25N, -...- H9	UP25N, UP25M -...- H12	UP25T -...- H12	UP50N, UP50M -...- W9	UP52N,UP 52M -...- QED	UP55N, UP60N -...- H9
Typical sensitivity	mV/J	0.14	0.05	0.05	0.020	0.012	0.028
Power sensitivity / energy sensitivity	J/W	1.67	2.19	2.19	5.28	4.37	4.25
Typical rise time in SSE mode	ms	370	1300	1300	1400	1200	1300
Minimum repetition period	sec	4.6	11.5	11.5	11.1	9	11.1
Maximum pulse width	ms	123	390	390	467	371	433
Maximum measurable energy ^a	J	40	40	40	500	1000	200
Noise equivalent energy	mJ	200	200	200	250	250	250
Accuracy	%	± 5	± 5	± 5%	± 5%	± 5%	± 5%

		UP55N UP55M -...- VR	UP55N, UP55M, UP60N, UP60M -...- H12	UP55G, UP60G -...- H12	UP55C -...- HD	UP55M, UP55G, UP60M, UP60G -...- HD	UP100R -...- H12
Typical sensitivity	mV/J	0.010	0.015	0.013	0.0025	0.008	0.0017
Power sensitivity / energy sensitivity	J/W	4.25	4.46	4.62	3.19	4.46	11.8
Typical rise time in SSE mode	ms	1300	1600	1800	855	1600	3200
Minimum repetition period	sec	11.1	12	14.3	11	12	30
Maximum pulse width	ms	433	430	433	210	430	1000
Maximum measurable energy ^a	J	500	200	200	200	200	700
Noise equivalent energy	mJ	250	250	250	1300	250	2000
Accuracy	%	± 5%	± 5	± 5	± 5	± 5	± 5

^a For 1,064 μm ; 360 μs pulses. Higher pulse energy possible when customized for long pulse (ms), lower for short pulses (ns).

Specifications subject to change without notice.

2. OPERATING INSTRUCTIONS

2.1. QUICK-START GUIDE

To make a measurement Gentec-EO monitor, continue with the following steps:

1. Install the detector in the optical setup
2. Ensure the proper cooling is provided.

For fan-cooled detectors, connect the fan to the proper power supply.

NOTE: The UP55G and UP60G must only be used with the Gentec-EO Power Supply P/N 202199.

For water-cooled detectors, connect the detector head to a cooling water supply. Refer to section 2.2 for details.

3. Remove the power detector cover.
4. Let the head thermally stabilize for at least 10 minutes before starting measurements.
5. Align the detector in the optical setup, using a safe low-powered beam.
6. For the most accurate measurements, the beam should be centered on the sensor face. The beam diameter on the sensor should ideally be the same size as the beam diameter of the original calibration, which corresponds to >98% encircled power centered on 50% of the sensor's surface (this complies with the International Electrotechnical Commission standard #1040: "Power and Energy Measuring Detector..."). Refer to your calibration certificate for the exact calibration beam diameter.

WARNING: Be careful not to exceed the maximum levels and densities stated in the specifications.

7. Connect the detector head to the input socket on the monitor (see the monitor's instruction manual).
8. Apply the laser beam to the detector for about one minute.
9. Block off the detector head to prevent it from sensing heat from random sources.
10. Wait until the signal has stabilized (fluctuations representing less than 1% of the voltage level being measured are negligible), then use the monitor's Zero (Offset) function to cancel out the offset from the detector. Strong fluctuations in the zero level are usually caused by one of the following:
 - a. Rapid fluctuations in the rate of water flow.
 - b. Rapid fluctuations in water temperature.
 - c. Strong drafts or stray radiation (especially for low-power measurements)
11. Apply the laser beam to the detector.
12. Wait until the signal has stabilized (between one to three minutes for optimum measurements), then measure the output from the detector.

2.2. MEASUREMENTS WITHOUT A GENTEC-EO MONITOR

To make a measurement without a Gentec-EO monitor, the following information should be taken into consideration.

Connect the power head to a precision microvoltmeter or data acquisition system with a load impedance that is > 100 k Ω (UP without internal circuit board) or with a load impedance > 10 M Ω (UP with internal circuit board). Because of the very low voltages at lower power levels for some of these detectors, analog or digital filtration may be required to remove ambient electrical noise.

Switch on the microvoltmeter and adjust its voltage range to the range required for the measurement. To determine the voltage range to be measured, refer to the detector's specifications:

$$V_{\text{out}} = (\text{expected power}) \times (\text{calibration sensitivity of power detector})$$

The measured power is calculated as follows:

$$\begin{aligned} \text{Measured power}[W] &= (V_{\text{out}}[V] - V_{\text{zero}}[V]) / \text{calibration sensitivity}[V/W] \\ &= (V_{\text{out}}[\text{mV}] - V_{\text{zero}}[\text{mV}]) / \text{calibration sensitivity}[\text{mV}/W] \end{aligned}$$

2.3. COOLING WATER

Water quality requirements:

- The diameter of the particles in the water must be below 60µm. Gentec-EO can provide an external water filter if water quality is an issue.
- The resistivity of the water must be over 100 kOhm-cm.
- The hardness must be below 10ppm.
- The pH must be between 6.0 to 8.0. (low pH will remove the protective oxide layer)

Water-cooled UPs are equipped with ¼" tube fittings.

NOTE: The end of the tube must be cut perpendicular to the tubing; the portion of the outer tubing wall that slips into the fitting must not be deformed or damaged, otherwise the connection will not be water-tight.

To connect the detector head fittings to the water supply tubing, unscrew the two parts of the fitting, push the tubing into the part not connected to the detector until it comes to the end of the fitting; then screw in the two parts of the fitting.

The direction of flow through the head is not important.

Once you have connected the fittings, check them for leaks. If you find a leak, check if the tubes are pushed in far enough and that the tubing has not been damaged.

Verify that the flow rate satisfies the minimum values, as indicated on the specifications pages. Variations of water flow rates or water temperature may cause corresponding oscillations in measurements.

To disconnect the detector head fittings, remove the water pressure and drain the water from the tubing. Unscrew the two parts of the fitting and pull out the tubing.

2.4. STORAGE NOTES

In order to ensure a long lifetime of accurate measurements, it is recommended that UP detectors be kept within the ambient conditions stated in the specifications.

NOTE: For water-cooled detectors, some water will usually remain in the detector head after it is disconnected. The detector should be completely dried out with an air flow before storage. Be careful not to blow the water on yourself or on the detector aperture.

2.5. SAFETY OPERATION NOTES

2.5.1. Diffusive surfaces

A portion of the laser radiation is not absorbed by the detector. Be aware of the diffused back reflection of the different absorbers:

- H and W: ~ 5-15%
- QED and VR: ~ 40-45%

As on any diffusive surface, the light on the absorber is scattered more or less uniformly as a Lambertian diffuser. It is recommended to use the detector with a black protective sleeve. This will limit wide-angled diffused reflections.

2.5.2. Detector temperature while in operation

During usage, especially close to the maximum power, detectors can become hot enough to cause burns.

2.6. USING A CUSTOMER-SUPPLIED HEATSINK

This is a special case. Standard detectors are calibrated and shipped with a Gentec-EO heatsink or cooling module installed. However, should the customer wish to install an alternative heatsink or cooling module, the following indications should be followed. This does not apply to the XLP, UP_P, UP_T, UP_M, and UP_G series.

Instructions :

1. Required specifications for customer-supplied back module are given in Fig 2-1 through 2-3. Note that tapped holes must be electrically conductive, and that there have to be at least bare spots to allow electrical contact with the detector (see point 5.).
2. While keeping together the front cover and the central housing, remove the four front screws of the UP detector.
3. Discard the back module.
4. Apply electrically-conductive silver epoxy on the bare contact zones of the back module (*Tra-Con, Tra-Duct no. BA-2902*). This will ensure proper electrical contact between the new back module and the central housing.
5. Apply thermal paste (such as *Wakefield Engineering Inc. thermal paste part no. 120-2*) on the remainder of the back module. This will ensure proper thermal contact with the new back module.
6. In the case that both central housing and back module are entirely bare and electrically conducting, a grease that is both thermally and electrically conductive (*Timtronics Black Ice 712*) may be applied, instead of steps 4. and 5.
7. Install the new back module onto the detector using the four original screws. It is strongly advised to apply removable thread locker (*Loctite removable thread locker 242*) on the screws before inserting them. The recommended torque for each of the 4 screws is 6 in.lbs. (70 Ncm).

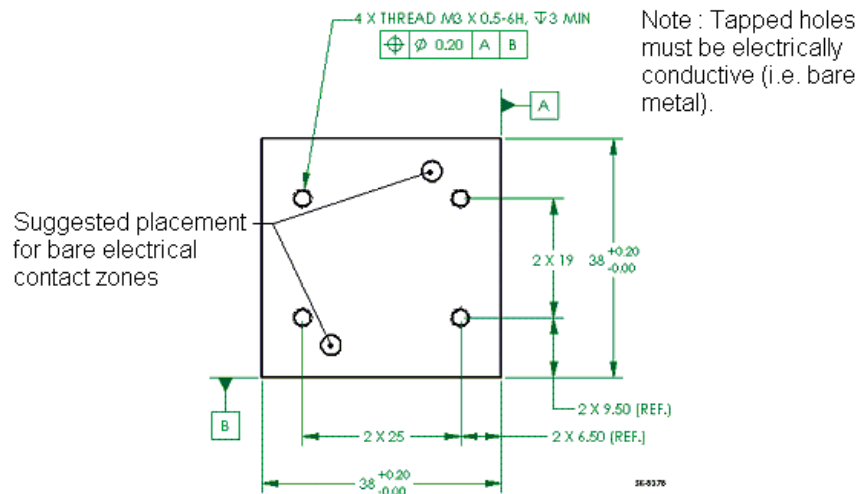

Fig. 2-1 Tapped hole positions for UP12E, without PCB

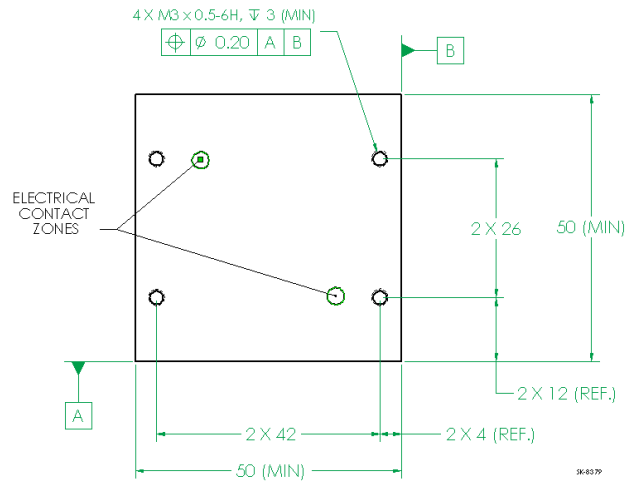

Fig 2-2 Tapped hole positions for UP10K, UP19K and UP19K

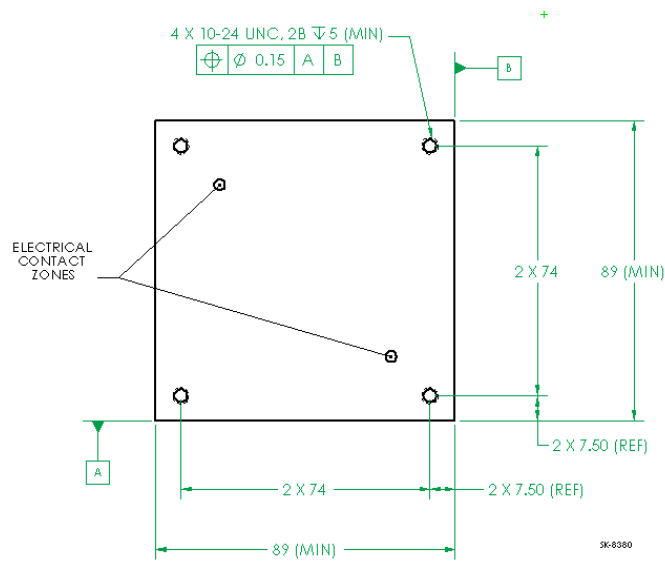

Fig 2-3 Tapped hole positions for UP25N, UP50N(M), UP55N(M), and UP60(M)

3. DAMAGE TO THE OPTICAL ABSORBER MATERIAL

Damage to the optical absorber material is usually caused by exceeding the manufacturer's specifications, such as:

- Incident average power density
- Incident pulse energy density

Refer to the specifications tables for the damage thresholds. Damage may also occur if the absorber surface is contaminated. A slight discoloration of the coating does not affect the calibration.

In any case, the beam's incident area should not be less than 10% of the detector's aperture. Please contact Gentec-EO to make measurements with such smaller beams.

In the event of significant damage to the absorber, some detectors can be recoated. Contact your local Gentec-EO representative for information on repair and recalibration.

3.1. DAMAGE THRESHOLD CURVES

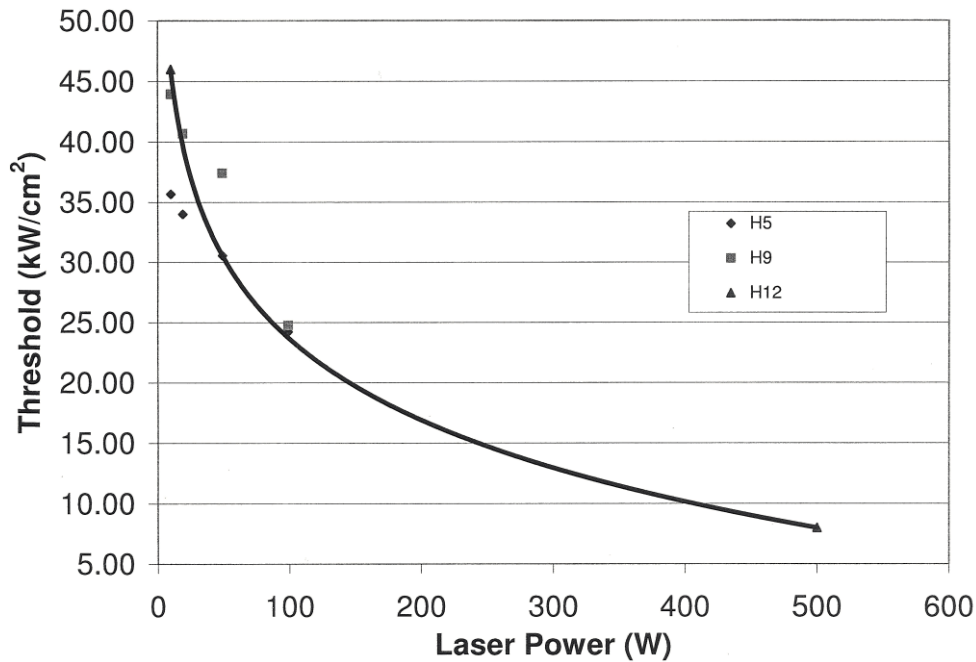

FIG. 3-1 Maximum average power density for detectors with H-type absorber at 1.064 μm .

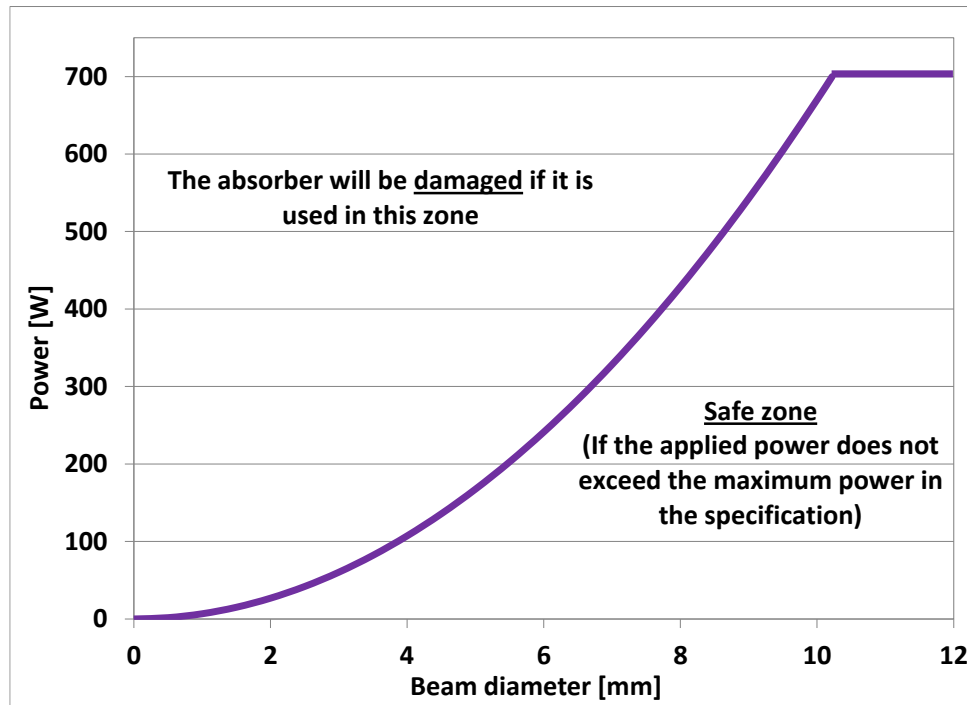

FIG. 3-2 Minimum beam sizes for detectors with H-type absorber at 1.064 μm . Note that the beam's incident area should not be less than 10% of the detector's aperture.

4. DECLARATION OF CONFORMITY



Application of Council Directive(s): 2014/30/EU EMC Directive

Manufacturer's Name: Gentec Electro Optics, Inc.
 Manufacturer's Address: 445 St-Jean Baptiste, suite 160
 (Québec), Canada G2E 5N7

Representative's Name: Laser Component S.A.S
 Representative's Address: 45 bis Route des Gardes
 92190 Meudon (France)

Type of Equipment: Laser Power/Energy Meter
 Model No.: UP, XLP series
 Year of test & manufacture: 2016

Standard(s) to which Conformity is declared: EN 61326-1: 2006 Emission generic standard

Standard	Description	Performance Criteria
CISPR 11 :2009 A1 :2010	Industrial, scientific and medical equipment – Radio-frequency disturbance characteristics – Limits and methods of measurement	Class A
EN 61000-4-2 2009	Electromagnetic compatibility (EMC) – Part 4-2: Testing and measurement techniques- Electrostatic discharge.	Class B
EN61000-4-3 2006+A2:2010	Electromagnetic compatibility (EMC) – Part 4-3: Testing and measurement techniques- Radiated, Radio Frequency, electromagnetic field immunity test.	Class A
EN61000-4-4 2012	Electromagnetic compatibility (EMC) – Part 4-4: Testing and measurement techniques- Electrical fast transient/burst immunity test.	Class B
EN 61000-4-5 2006	Electromagnetic compatibility (EMC) – Part 4-5: Testing and measurement techniques- Surge immunity test.	Class B
EN 61000-4-6 2013	Electromagnetic compatibility (EMC) – Part 4-6: Testing and measurements techniques- Immunity to conducted Radio Frequency.	Class A
EN 61000-4-11 2004	Electromagnetic compatibility (EMC) – Part 4-11: Testing and measurement techniques- Voltage dips, short interruptions and voltage variations immunity tests. Voltage dips: 0% during 1 cycle 40% during 10 cycles 70% during 25 cycles Short interruptions: 0% during 250 cycles	Class B Class B Class C Class C
EN 61000-3-2:2006 +A1:2009	Electromagnetic compatibility (EMC) - Part 3-2: Limits - Limits for harmonic current emissions (equipment input current <= 16 A per phase)	Class A

I, the undersigned, hereby declare that the equipment specified above conforms to the above Directive(s) and Standard(s)

Place: Quebec (Quebec)
 Date: July 14 2016

(President)

5. UKCA DECLARATION OF CONFORMITY

Application of Council Directive(s): 2014/30/EU EMC Directive



Manufacturer's Name: Gentec Electro Optics, Inc.
 Manufacturer's Address: 445 St-Jean Baptiste, suite 160
 (Québec), Canada G2E 5N7

Representative's Name: Laser Component S.A.S
 Representative's Address: 45 bis Route des Gardes
 92190 Meudon (France)

Type of Equipment: Laser Power/Energy Meter
 Model No.: UP, XLP series
 Year of test & manufacture: 2016

Standard(s) to which Conformity is declared: EN 61326-1: 2006 Emission generic standard

Standard	Description	Performance Criteria
CISPR 11 :2009 A1 :2010	Industrial, scientific and medical equipment – Radio-frequency disturbance characteristics – Limits and methods of measurement	Class A
EN 61000-4-2 2009	Electromagnetic compatibility (EMC) – Part 4-2: Testing and measurement techniques- Electrostatic discharge.	Class B
EN61000-4-3 2006+A2:2010	Electromagnetic compatibility (EMC) – Part 4-3: Testing and measurement techniques- Radiated, Radio Frequency, electromagnetic field immunity test.	Class A
EN61000-4-4 2012	Electromagnetic compatibility (EMC) – Part 4-4: Testing and measurement techniques- Electrical fast transient/burst immunity test.	Class B
EN 61000-4-5 2006	Electromagnetic compatibility (EMC) – Part 4-5: Testing and measurement techniques- Surge immunity test.	Class B
EN 61000-4-6 2013	Electromagnetic compatibility (EMC) – Part 4-6: Testing and measurements techniques- Immunity to conducted Radio Frequency.	Class A
EN 61000-4-11 2004	Electromagnetic compatibility (EMC) – Part 4-11: Testing and measurement techniques- Voltage dips, short interruptions and voltage variations immunity tests. Voltage dips: 0% during 1 cycle 40% during 10 cycles 70% during 25 cycles Short interruptions: 0% during 250 cycles	Class B Class B Class C Class C
EN 61000-3-2:2006 +A1:2009	Electromagnetic compatibility (EMC) - Part 3-2: Limits - Limits for harmonic current emissions (equipment input current <= 16 A per phase)	Class A

I, the undersigned, hereby declare that the equipment specified above conforms to the above Directive(s) and Standard(s)

Place: Quebec (Quebec)
 Date : December 02, 2021

(President)

APPENDIX A: WEEE DIRECTIVE

RECYCLING AND SEPARATION PROCEDURE FOR WEEE DIRECTIVE 2002/96/EC:

This section is used by the recycling center when the detector reaches its end of life. Breaking the calibration seal or opening the monitor will void the detector's warranty.

The complete detector contains

- 1 detector with cable or DB15.
- 1 calibration certificate
- 1 electronic PCB (INTEGRA and BLU options)
- 1 plastic enclosure (INTEGRA option)

SEPARATION

Paper: Calibration certificate

Wires: Detector cable

Printed circuit board: inside the detector (for -MT, -MA, -BT and -CP version only) or DB15, no need to separate (less than 10 cm²). Inside the INTEGRA enclosure, no need to separate (less than 10 cm²).

Aluminum: Detector casing

Plastic: INTEGRA enclosure

APPENDIX B: USING THE XLP12 WITH THE XLP12 FILTER

The XLP12 filter features simple installation and removal. To use an XLP12 series power meter (at any wavelength) with the XLP12 filter, the user must calibrate the assembly using the following procedure:

- Step 1: Set up the XLP12 detector without the filter to measure the power of your laser. Adjust its sensitivity to your working wavelength. Verify that the power level is below the detector's damage threshold and that the laser is stable.
- Step 2: Warm up the detector by applying power to it for a few minutes. This will reduce thermal bias.
- Step 3: Measure the power level (without the filter). To reduce random uncertainty, we recommend taking the average of 5 distinct measurements.
- Step 4: Install the filter. Without changing the laser settings, measure the power level by averaging the same number of distinct measurements as in Step 3. All laser settings remain identical as in Step 3, including beam size and position on the detector.
- Step 5: Repeat the first measurement (Step 3) to verify that there hasn't been any change during the procedure that would invalidate the calibration. A difference that is larger than the uncertainty of your measurement means that something in the laser or environment has changed. You may add this to your \pm uncertainty when using the filter, or you may try stabilizing the laser and environment and repeat from Step 3.

The correction multiplier will be given by:

$$T_f = \frac{\text{Reading without attenuator}}{\text{Reading with attenuator}} \text{ (no units)}$$

The correction factor for the Duo (prior to rev 2.0) will be:

$$F_s = \frac{100}{T_f} (\%)$$

XLP12 Filter	
Spectral range	280 nm – 1.36 μm
Typical transmittance (@ 1.064 μm)	93 %
Typical reflectance (@ 1.064 μm)	7 %
Dimensions (installed in own mount and XLP12, ext. \varnothing x thickness)	1.2 " \varnothing x 1/3 "

APPENDIX C: USING THE XLP12 WITH AN OPTICAL FIBER ADAPTOR

NOTE: Gentec-EO detectors are calibrated in free-space conditions. Adding adaptors or accessories close to the absorber can offset the measurements.

When fitted with an appropriate adaptor, such as Gentec-EO's FC Optical Fiber Connector, the XLP12 can be used to measure the output of an optical fiber. When using an optical fiber adaptor, it is the user's responsibility to ensure that the entire output of the fiber is incident upon the detector's absorbing surface. Figure C-1 and the following inequation are provided as a guide to verify this.

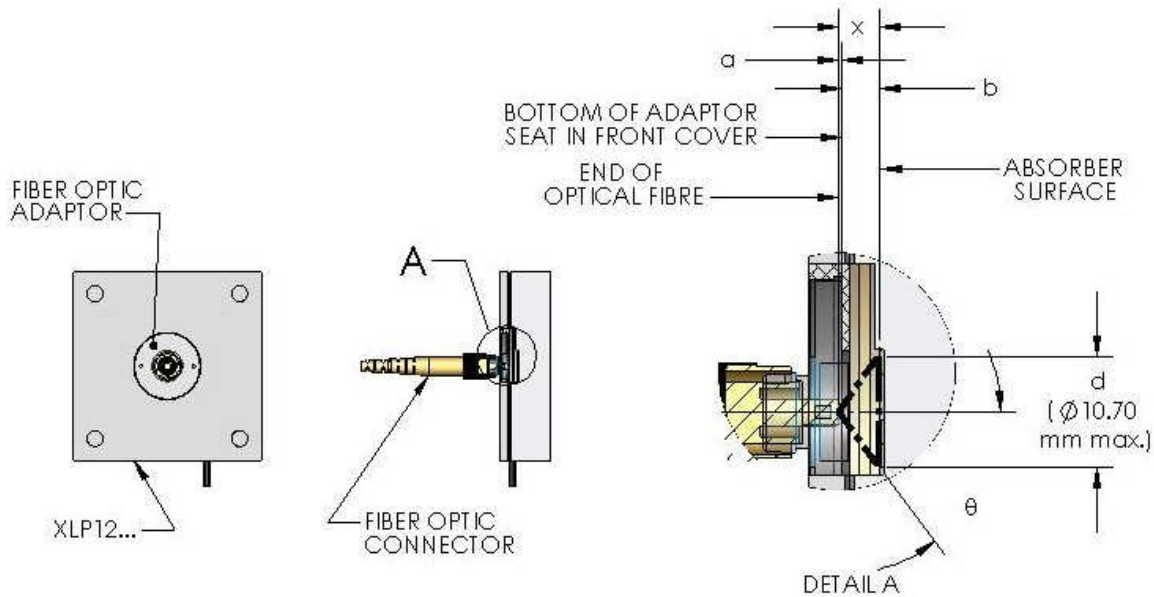

Fig. C-1 Using an optical fiber adaptor

For the XLP12, the distance between the absorbing surface and the adaptor seat is $b = 3.75 \pm 0.5$ mm. The diameter corresponding to 80% of the absorbing surface (80% is a common value for allowing sufficient margin to avoid edge effects) is $d = 10.7$ mm. The acceptance angle θ of the fiber is specific to the user's fiber, as is the value of a , the distance in mm between the end of the fiber and the interface between the adaptor and its seat on the detector. This value can be measured once the user's fiber is connected to the fiber adaptor (a typical value may be $a = 0.2$ mm). Once known, the values θ and a can be entered in the following inequation:

$$(a + 4) \tan \theta < 5.35$$

where 5.35 is $d/2$. If the inequation is verified, then it is safe to consider that the light cone, having a height $x = a + b$ and a maximum diameter d , exiting the fiber is entirely incident on 80% of the measuring surface of the detector.

APPENDIX D. CUSTOM AND DISCONTINUED MODELS

These tables are presented for convenient reference only. For discontinued models, contact us for the most accurate specifications. For custom products, refer to the specifications included with your order.

	UP19K-100DI-H5	UP19K-150W-H5	UP19K-150DI-H9
Effective aperture diameter	19 mm		
Aperture threading	0.782"-32 Optional cover plate available with SM1 thread and 10 mm aperture		
Spectral range	0.19 - 20 μm		
Calibrated spectral range	0.248 - 2.1 μm		
Available extra calibrated ranges	2.1 - 2.5 μm <u>OR</u> 10.6 μm		
Max. average power	100 W	150 W (190 W for 1 min)	150 W
Power noise level	± 2 mW with anticipation ± 1 mW without anticipation		± 6 mW with anticipation ± 3 mW without anticipation
Typical rise time (0-95 %)	0.6 s		1.5 s
Natural rise time (0-95 %)	2.8 s		4.5 s
Typical sensitivity	0.65 mV/W		0.23 mV/W
Calibration uncertainty	± 2.5 %		
Linearity with power	± 2 %		
Repeatability (precision)	± 0.5 %		
Linearity vs beam dimension	± 0.5 %		
Max. average power density 1.064 μm , 10 W CW 10.6 μm , 10 W CW	36 kW/cm ² 11 kW/cm ²		45 kW/cm ² 14 kW/cm ²
Pulsed laser damage thresholds 1.064 μm , 360 μs , 5 Hz 1.064 μm , 7 ns, 10 Hz 532 nm, 7 ns, 10 Hz 266 nm, 7 ns, 10 Hz	5 J/cm ² 1.0 J/cm ² 0.6 J/cm ² 0.3 J/cm ²		9 J/cm ² 1.0 J/cm ² 0.6 J/cm ² 0.3 J/cm ²
Recommended cooling flow	1.0 L/min (minimum: 0.5 L/min) 1.0 L/min minimum when measuring > 90 W with DI detectors		
Cooling	Water	Water	Water
Dimensions (H x W x D, mm)	50 x 50 x 33	50 x 50 x 33	50 x 50 x 33
Weight (head only)	0.42 kg	0.24 kg	0.42 kg

	UP19K-15S-VR	UP19K-30H-VR
Effective aperture diameter	18 mm	
Spectral range	0.266 - 2.5 μm	
Calibrated spectral range	0.30 - 2.1 μm	
Available extra calibrated ranges	2.1 - 2.5 μm	
Max. average power	15 W (20 W for 1 min)	30 W (35 W for 1 min)
Power noise level	± 4 mW with anticipation ± 2 mW without anticipation	
Typical rise time (0-95 %)	2.5 s	
Natural rise time (0-95 %)	36 s	
Typical sensitivity	0.34 mV/W	
Calibration uncertainty	± 2.5 %	
Linearity with power	± 2 %	
Repeatability (precision)	± 0.5 %	
Linearity vs beam dimension	± 0.5 %	
Max. average power density 1.064 μm , 10 W CW	700 W/cm ²	
Pulsed laser damage thresholds 1.064 μm , 360 μs , 10 Hz 1.064 μm , 7 ns, 10 Hz 532 nm, 7 ns, 10 Hz 266 nm, 7 ns, 10 Hz	40 J/cm ² 6 J/cm ² 4 J/cm ² 1 J/cm ²	
Cooling	Stand-alone	Heatsink
Dimensions (H x W x D, mm)	50 x 50 x 20.6	50 x 50 x 56.3
Weight (head only)	0.16 kg	0.21 kg

	UP19K-50DI-W5
Effective aperture diameter	19 mm
Spectral range	0.19 - 10 μm
Calibrated spectral range	0.248 - 2.1 μm
Available extra calibrated ranges	2.1 - 2.5 μm
Max. average power	50 W (85 W for 1 min)
Power noise level	± 2 mW with anticipation ± 1 mW without anticipation
Typical rise time (0-95 %)	1.4 s
Natural rise time (0-95 %)	5 s
Typical sensitivity	0.65 mV/W
Calibration uncertainty	± 2.5 %
Linearity with power	± 2 %
Repeatability (precision)	± 0.5 %
Linearity vs beam dimension	± 0.5 %
Max. average power density 1.064 μm , 10 W CW	100 kW/cm ²
Pulsed laser damage thresholds	
1.064 μm , 150 μs , 10 Hz	100 J/cm ²
1.064 μm , 7 ns, 10 Hz	1.1 J/cm ²
532 nm, 7 ns, 10 Hz	1.1 J/cm ²
248 nm, 26 ns, 10 Hz	0.7 J/cm ²
Recommended cooling flow	1.0 L/min (0.5 L/min minimum)
Cooling	Water
Dimensions (H x W x D, mm)	50 x 50 x 33
Weight (head only)	0.42 kg

	UP25T-15S-H12	UP25T-250W-H12
Effective aperture diameter	25 mm	
Spectral range	0.19 - 20 μm	
Calibrated spectral range	0.248 - 2.1 μm	
Available extra calibrated ranges	2.1 - 2.5 μm <u>OR</u> 10.6 μm	
Max. average power	15 W	250 W
Power noise level	± 20 mW with anticipation ± 10 mW without anticipation	
Typical rise time (0-95 %)	1.3 s	
Natural rise time (0-95 %)	7.9 s	
Typical sensitivity	0.1 mV/W	
Calibration uncertainty	± 2.5 %	
Linearity with power	± 2 %	
Repeatability (precision)	± 0.5 %	
Linearity vs beam dimension	± 0.5 %	
Max. average power density 1.064 μm , 10 W CW 10.6 μm , 10 W CW	45 kW/cm ² 14 kW/cm ²	
Pulsed laser damage thresholds 1.064 μm , 360 μs , 5 Hz 1.064 μm , 7 ns, 10 Hz 532 nm, 7 ns, 10 Hz 266 nm, 7 ns, 10 Hz	9 J/cm ² 1.0 J/cm ² 0.6 J/cm ² 0.3 J/cm ²	
Recommended cooling flow	N/A	1.5 L/min
Cooling	Heatsink	Water
Dimensions (H x W x D, mm)	62.4 x 62.4 x 38.1	62.4 x 62.4 x 38.1
Weight (head only)	0.31 kg	0.33 kg

	UP50N-40S-W9	UP50N-50H-W9	UP50M-50W-W9
Aperture diameter	50 mm		
Spectral range	0.19 - 10 μm		
Calibrated spectral range	0.248 - 2.1 μm		
Available extra calibrated ranges	2.1 - 2.5 μm		
Max. average power	40 W (80 W for 1 min)	50 W (85 W for 1 min)	50 W (85 W for 1 min)
Power noise level	± 10 mW with anticipation ± 5 mW without anticipation		
Typical rise time (0-95 %)	3.5 s		
Natural rise time (0-95 %)	16 s		
Typical sensitivity	0.12 mV/W		
Calibration uncertainty	± 2.5 %		
Linearity with power	± 2 %		
Repeatability (precision)	± 0.5 %		
Linearity vs beam dimension	± 0.5 %		
Max. average power density 1.064 μm , 10 W CW	100 kW/cm ²		
Pulsed laser damage thresholds 1.064 μm , 150 μs , 5 Hz 1.064 μm , 7 ns, 10 Hz 532 nm, 7 ns, 10 Hz 248 nm, 26 ns, 10 Hz	100 J/cm ² 1.1 J/cm ² 1.1 J/cm ² 0.7J/cm ²		
Minimum cooling flow	N/A		1 L/min
Cooling	Stand-alone	Heatsink	Water
Dimensions (H x W x D, mm)	89 x 89 x 32	89 x 89 x 106	89 x 89 x 40
Weight (head only)	0.62 kg	0.93 kg	0.81 kg

	UP55N-300DI-H12	UP55N-400DI-HD	UP60N-300DI-H12
Effective aperture diameter	55 mm		60 mm
Spectral range	0.19 - 20 μm		
Calibrated spectral range	0.248 - 2.1 μm		
Available extra calibrated ranges	2.1 - 2.5 μm <u>QR</u> 10.6 μm		
Max. average power	300 W	400 W	300 W
Power noise level	± 30 mW with anticipation ± 15 mW without anticipation	± 90 mW with anticipation ± 45 mW without anticipation	± 30 mW with anticipation ± 15 mW without anticipation
Typical rise time (0-95 %)	2 s	2.8 s	2 s
Natural rise time (0-95 %)	18 s	14 s	18 s
Typical sensitivity	0.06 mV/W	0.03 mV/W	0.06 mV/W
Calibration uncertainty	± 2.5 %		
Linearity with power	± 2 %		
Repeatability (precision)	± 0.5 %		
Linearity vs beam dimension	± 0.5 %		
Max. average power density 1.064 μm , 10 W CW 10.6 μm , 10 W CW	45 kW/cm ² 14 kW/cm ²		
Pulsed laser damage thresholds 1.064 μm , 360 μs , 5 Hz 1.064 μm , 7 ns, 10 Hz 532 nm, 7 ns, 10 Hz 266 nm, 7 ns, 10 Hz	9 J/cm ² 1.0 J/cm ² 0.6 J/cm ² 0.3 J/cm ²		
Recommended cooling flow	1.5 L/min		
Cooling	Water	Water	Water
Dimensions (H x W x D, mm)	89 x 89 x 44	89 x 89 x 44	89 x 89 x 44
Weight (head only)	1.68 kg	1.68 kg	1.68 kg

	UP60N-40S-H9	UP60N-100H-H9	UP60N-300F-H12	UP60M-500W-H12	UP60M-700W-HD
Aperture diameter	60 mm				
Spectral range	0.19 - 20 μm				
Calibrated spectral range	0.248 - 2.1 μm				
Available extra calibrated ranges	2.1 - 2.5 μm <u>OR</u> 10.6 μm				
Max. average power	40 W (80 W for 1 min)	100 W (200 W for 1 min)	300 W	500 W	700 W
Power noise level	± 10 mW with anticipation ± 5 mW without anticipation		± 30 mW with anticipation ± 15 mW without anticipation		± 90 mW with anticipation ± 45 mW without anticipation
Typical rise time (0-95 %)	2 s				2.8 s
Natural rise time (0-95 %)	11 s		18 s		14 s
Typical sensitivity	0.12 mV/W		0.06 mV/W		0.03 mV/W
Calibration uncertainty	± 2.5 %				
Linearity with power	± 2 %				
Repeatability (precision)	± 0.5 %				
Linearity vs beam dimension	± 0.5 %				
Max. average power density 1.064 μm , 10 W CW 10.6 μm , 10 W CW	45 kW/cm ² 14 kW/cm ²				
Pulsed laser damage thresholds 1.064 μm , 360 μs , 5 Hz 1.064 μm , 7 ns, 10 Hz 532 nm, 7 ns, 10 Hz 266 nm, 7 ns, 10 Hz	9 J/cm ² 1.0 J/cm ² 0.6 J/cm ² 0.3 J/cm ²				
Minimum cooling flow	N/A			1.5 L/min	
Cooling	Stand-alone	Heatsink	Fan	Water	Water
Dimensions (H x W x D, mm)	89 x 89 x 32	89 x 89 x 106	89 x 89 x 116	89 x 89 x 40	89 x 89 x 40
Weight (head only)	0.62 kg	0.93 kg	1.41 kg	0.81 kg	0.90 kg

	UP55N-50S-VR	UP55N-100H-VR	UP55N-150F-VR	UP55M-200W-VR
Aperture diameter	55 mm			
Spectral range	0.30 - 2.5 μm			
Calibrated spectral range	0.30 - 2.1 μm			
Available extra calibrated ranges	2.1 - 2.5 μm			
Max. average power	50 W	100 W	150 W	200 W
Power noise level	± 30 mW with anticipation ± 15 mW without anticipation			
Typical rise time (0-95 %)	4 s			
Natural rise time (0-95 %)	50 s			
Typical sensitivity	0.04 mV/W			
Calibration uncertainty ^f	± 2.5 %			
Linearity with power	± 2 %			
Repeatability (precision)	± 0.5 %			
Linearity vs beam dimension	± 0.5 %			
Max. average power density 1.064 μm , 10 W CW	700 W/cm ²			
Pulsed laser damage thresholds 1.064 μm , 360 μs , 5 Hz 1.064 μm , 7 ns, 10 Hz 532 nm, 7 ns, 10 Hz 266 nm, 7 ns, 10 Hz	40 J/cm ² 6 J/cm ² 4 J/cm ² 1 J/cm ²			
Minimum cooling flow	N/A			1 L/min
Cooling	Stand-alone	Heatsink	Fan	Water
Dimensions (H x W x D, mm)	89 x 89 x 32	89 x 89 x 106	89 x 89 x 116	89 x 89 x 40
Weight (head only)	0.62 kg	0.93 kg	1.41 kg	0.84 kg

	UP55G-500F-H12	UP60G-400F-H12	UP60G-500F-HD
Aperture diameter	55 mm	60 mm	
Spectral range	0.19 - 20 μm		
Calibrated spectral range	0.248 - 2.1 μm		
Available extra calibrated ranges	2.1 - 2.5 μm <u>OR</u> 10.6 μm		
Max. average power	500 W	400 W	500 W
Power noise level	± 30 mW with anticipation ± 15 mW without anticipation	± 90 mW with anticipation ± 45 mW without anticipation	
Typical rise time (0-95 %)	3.5 s	5 s	
Natural rise time (0-95 %)	16.6 s	14 s	
Typical sensitivity	0.06 mV/W	0.03 mV/W	
Calibration uncertainty	$\pm 2.5\%$		
Linearity with power	$\pm 2\%$		
Repeatability (precision)	$\pm 0.5\%$		
Linearity vs beam dimension	$\pm 0.5\%$		
Max. average power density 1.064 μm , 10 W, CW 1.064 μm , 500 W, CW	45 kW/cm ² 8 kW/cm ²		
Pulsed laser damage thresholds 1.064 μm , 360 μs , 5 Hz 1.064 μm , 7 ns, 10 Hz 532 nm, 7 ns, 10 Hz 266 nm, 7 ns, 10 Hz	9 J/cm ² 1.0 J/cm ² 0.6 J/cm ² 0.3 J/cm ²		
Cooling	Fan		
Dimensions (H x W x D, mm)	120 x 120 x 135		
Weight (head only)	2.75 kg		

LEADER IN LASER BEAM MEASUREMENT SINCE 1972



POWER & ENERGY METERS



BEAM PROFILING



THZ MEASUREMENT

CANADA

445 St-Jean-Baptiste, Suite 160
Quebec, QC, G2E 5N7
CANADA

T (418) 651-8003
F (418) 651-1174

info@gentec-eo.com

UNITED STATES

5825 Jean Road Center
Lake Oswego, OR, 97035
USA

T (503) 697-1870
F (503) 697-0633

info@gentec-eo.com

JAPAN

Office No. 101, EXL111 building,
Takinogawa, Kita-ku, Tokyo
114-0023, JAPAN

T +81-3-5972-1290
F +81-3-5972-1291

info@gentec-eo.com

CALIBRATION CENTERS

- 445 St-Jean-Baptiste, Suite 160
Quebec, QC, G2E 5N7, CANADA
- Werner von Siemens Str. 15
82140 Olching, GERMANY
- Office No. 101, EXL111 building,
Takinogawa, Kita-ku, Tokyo
114-0023, JAPAN